



product list

COMPANY PROFILE

Foshan Jackbond Electromechanical Manufacturing Co., Ltd. specializes in the production and design of Jackbond p brand woodworking machinery, including portable edge banding machines, manual edge banding machines, automatic edge banding machines, woodworking cutting machines, woodworking punching machines, end round machines and many others Manual or electric tool facilities and accessories. High starting point, high quality and high technical level products have enabled our products to enter the market strongly, and have obtained CQC and CE certification. Our sales network covers China as well as Europe, America, Middle East and Southeast regions. "Customer first, quality first" is deeply imprinted in Jackbond's mind. We will build a first-class enterprise with a harmonious, pragmatic, innovative, careful and exquisite purpose and a high-quality heart.



Design, research and development capabilities

— The company accumulates many years of manufacturing experience, fully implements a modern management model from product development, design, production, sales, service and other links, and establishes a quality and environmental management system in accordance with ISO9001 international standards. The production equipment is advanced, and some international standard complete sets of equipment and advanced testing instruments have been introduced, and the product quality is stable and reliable.

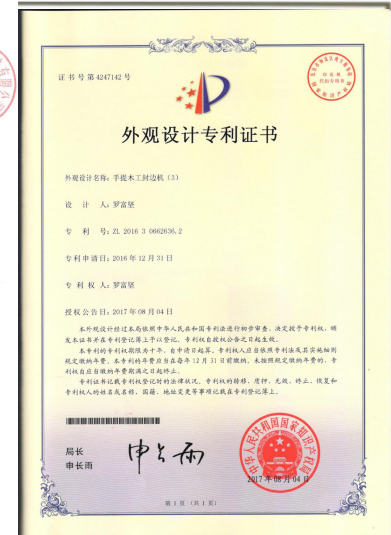
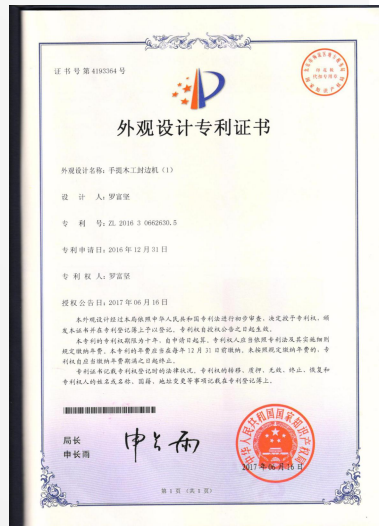

product description



1

edge banding machine

2

Woodworking machine

3

Woodworking copy type corner trimming machine

4

Single motor saw table

5

Air compressor

6

electrical tools

7

Woodworking tools

8

Toolbox

9

High quality hot melt edge banding glue

10

Accessories



Portable edge banding machine



Product number: JBD80
Net weight: 9.5 kg
Dimensions: 340×310×350MM
Total power: 765 watts
Voltage: 220V/110V, 50~60 Hz
Edge band thickness: 0.3-3MM
Edge band width: 10-45MM
Feed speed: 5 m/min
Working temperature: 120-180°C
Gluing method: single-sided gluing
Gross weight: 14 kg
Volume: 380×300×420MM



Product number: JBT90
Net weight: 9.5 kg
Dimensions: 340×310×350MM
Total power: 765 watts
Voltage: 220V/110V, 50~60 Hz
Edge band thickness: 0.3-3MM
Edge band width: 10-45MM
Feed speed: 0.5-5 m/min
Working temperature: 120-180°C
Gluing method: single-sided gluing
Gross weight: 14 kg
Volume: 380×300×420MM

Portable edge banding machine



Product number: JBT102B
Net weight: 11 kg
Dimensions: 380×300×310MM
Total power: 1000 watts
Voltage: 220V/110V, 50~60 Hz
Edge band thickness: 0.3-3MM
Edge band width: 10-60MM
Feed speed: 0.5-5 m/min
Working temperature: 120-180°C
Gluing method: double-sided gluing
Gross weight: 16 kg
Volume: 370×350×420MM



Product number: JBT102C
Net weight: 11 kg
Dimensions: 380×300×310MM
Total power: 1000 watts
Voltage: 220V/110V, 50~60 Hz
Edge band thickness: 0.3-3MM
Edge band width: 10-60MM
Feed speed: 0.5-5 m/min
Working temperature: 120-180°C
Gluing method: double-sided gluing
Gross weight: 16 kg
Volume: 370×350×420MM

Desktop edge banding machine



Product number: JBT180
Net weight: 37 kg
Dimensions: 500×570×570MM
Total power: 1150 watts
Voltage: 220V/110V, 50~60 Hz
Edge band thickness: 0.3-3MM
Edge band width: 10-60MM
Feed speed: 0.5-5 m/min
Working temperature: 120-180°C
Gluing method: double-sided gluing
Gross weight: 40.5 kg
Volume: 635×595×670MM



Product number: JBT180L
Net weight: 38 kg
Dimensions: 500×575×570MM
Total power: 1150 watts
Voltage: 220V/110V, 50~60 Hz
Edge band thickness: 0.3-3MM
Edge band width: 10-60MM
Feed speed: 0.5-5 m/min
Working temperature: 120-180°C
Gluing method: double-sided gluing
Gross weight: 41.5 kg
Volume: 635×595×670MM

Rocker arm edge banding machine

1



Automatic edge banding, trimming, end-cutting all-in-one machine

model: EX235C

Net weight: 50 kg

Dimensions: 1050×490×490mm

Total power: 2600 watts

Voltage: 220V/110V, 50~60 Hz

Edge band thickness: 0.3-3mm

Edge band width: 10-60mm

Feed speed: 0.5-5 m/min

Working temperature: 120-180°C

Gluing method: double-sided glue

Gross weight: 52 kg

Volume: 1070×500×500mm

2



Portable edge banding, trimming, all-in-one machine

model: EX235

Net weight: 57 kg

Dimensions: 1380×530×510mm

Total power: 2020 watts

Voltage: 220V/110V, 50~60 Hz

Edge band thickness: 0.3-3mm

Edge band width: 10-60mm

Feed speed: 0.5-5 m/min

Working temperature: 120-180°C

Gluing method: double-sided gluing

Gross weight: 60kg

Volume: 810×510×510mm

3

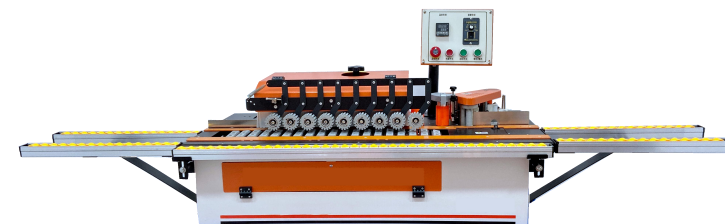

Automatic edge banding, trimming, all-in-one machine

model: EX236

Net weight: 85 kg

Dimensions: 2170×880×690mm

Total power: 2115 watts

Voltage: 220V/110V, 50~60 Hz

Edge band thickness: 0.3-3mm

Edge band width: 10-60mm

Feed speed: 0.5-5 m/min

Working temperature: 120-180°C

Gluing method: double-sided glue

Gross weight: 110 kg

Volume: 1200×570×660mm

Rocker arm edge banding machine

1



Automatic edge banding, trimming, end-cutting all-in-one machine
model: EX236C
Net weight: 75 kg
Dimensions: 1200×540×720mm
Total power: 3135 watts
Voltage: 220V/110V, 50~60 Hz
Edge band thickness: 0.3~3mm
Edge band width: 10~60mm
Feed speed: 0.5~5 m/min
Working temperature: 120~180°C
Gluing method: double-sided glue
Gross weight: 81 kg
Volume: 1320×530×630mm

2



Automatic edge banding, trimming, end-cutting all-in-one machine
model: EX236
Net weight: 85 kg
Dimensions: 2170×880×690mm
Total power: 3515 watts
Voltage: 220V/110V, 50~60 Hz
Edge band thickness: 0.3~3mm
Edge band width: 10~60mm
Feed speed: 0.5~5 m/min
Working temperature: 120~180°C
Gluing method: double-sided glue
Gross weight: 130 kg
Volume: 1200×570×660mm

3



High-speed automatic edge banding machine
Product model: EX237
Dimensions 190*89*112cm
Overall weight: 122kg
Edge Banding Type Straight Sheet
Voltage 220V total power 4kw
Edge band height: 10~60mm
Edge band thickness: 0.3~3mm
Minimum length of plate: 200mm
Minimum width of plate: 100mm
Speed: 0~10m/min
Transmission speed 0~10m/min
All wooden box packing size: 138*62*107cm
Total Weight: 150KGS

Rocker arm edge banding machine

1



High-speed automatic edge banding machine
Product model:EX230
Dimensions 190*56*112cm
Overall weight: 98kg
Voltage 220V
total power: 4kw
Edge band height: 10~60mm
Edge band thickness: 0.3~3mm
Speed: 0~10m/min
Transmission speed 0~5m/min
All carton box packing size:135*60*63cm
Total Weight:105KGS

2



High-speed automatic edge banding machine
Product model:EX231
Dimensions 210*57*112cm
Overall weight: 98kg
Voltage 220V
total power: 4.1kw
Edge band height: 10~60mm
Edge band thickness: 0.3~3mm
Speed: 0~10m/min
Transmission speed 0~10m/min
All carton box packing size:158*61*68cm
Total Weight:174KGS

3



High-speed automatic edge banding machine
Product model:EX230
Dimensions 190*56*112cm
Overall weight: 113kg
Voltage 220V
total power: 4kw
Edge band height: 10~60mm
Edge band thickness: 0.3~3mm
Speed: 0~10m/min
Transmission speed 0~5m/min
All carton box packing size:135*60*63cm
Total Weight:120KGS

Automatic edge banding machine



Automatic edge banding machine
Model: JBT190
Net weight: 63 kg
Dimensions: 141×55×98cm
Total power: 1500watts
Voltage: 220V/110V, 50~60 Hz
Edge band thickness: 0.3-3mm
Edge band width: 10-60mm
Feed speed: 0.5-5 m/min
Working temperature: 120-180°C
Gluing method: double-sided glue
Gross weight: 62 kg
Volume: 870×510×510mm



Automatic edge banding machine
Model: JB760
Net weight: 50 kg
Dimensions: 1200×500×500mm
Total power: 1000 watts
Voltage: 220V/110V, 50~60 Hz
Edge band thickness: 0.3-3mm
Edge band width: 10-60mm
Feed speed: 0.5-5 m/min
Working temperature: 120-180°C
Gluing method: double-sided glue
Gross weight: 52 kg
Volume: 1220×520×520mm

Automatic edge banding machine



High-speed automatic edge banding machine
Product model: JB1800
Dimensions 220*65*125cm
Overall weight: 320kg
Edge Banding Type Straight Sheet
Voltage 380V total power 4.9kw
Edge band height: 10~50mm
Edge band thickness: 0.3~3mm
Minimum length of plate: 200mm
Minimum width of plate: 100mm
Speed: 0~10m/min
Transmission speed 0~10m/min
All wooden box packing size: 207*84*135cm
Total Weight: 350KGS



High-speed automatic edge banding machine
Product model: F200
Dimensions 2150*620*1250mm
Overall weight: 240kg
Edge Banding Type Straight Sheet
Voltage 220V total power 4.9kw
Edge band height: 10~60mm
Edge band thickness: 0.3~3mm
Minimum length of plate: 140mm
Minimum width of plate: 80mm
Speed: 0~10m/min
Transmission speed 0~10m/min
All wooden box packing size: 194*66*112cm
Total Weight: 300KGS

Rocker arm edge banding machine

1

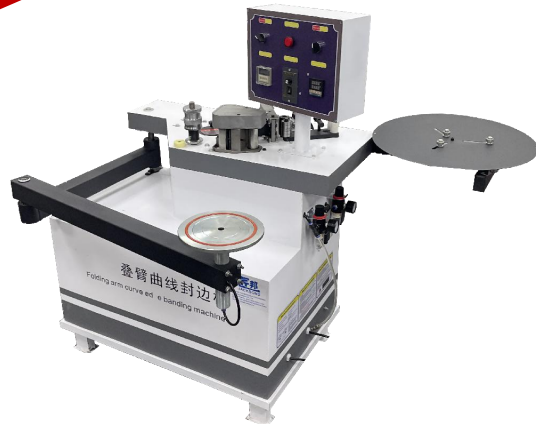

Product number: JBF-W1
Net weight: 88kg
wooden box packing size: 105*65*120cm
Power supply voltage: 220v 50Hz
Gross weight: 110KG
Motor power: 0.18kw
Dimensions: 91*70*121cm
Heating power: 1.2kw
Total power: 1.4kw
Air pressure: 3-8Mpa
Edge banding width: 8-50mm
Edge banding thickness: 0.3-3mm
Edge banding speed: 0-26cm/s
Edge banding material: PVC veneer, melamine plastic and other materials

2



Product number: JBF-W2
Net weight: 120kg
Dimensions: 120*80*125cm
wooden box packing size: 125*85*100cm
Gross weight: 140KG
Power supply voltage: 220v 50Hz
Motor power: 0.18kw
Heating power: 1.2kw
Total power: 1.4kw
Air pressure: 3-8Mpa
Edge banding width: 8-50mm
Edge banding thickness: 0.3-3mm
Edge banding speed: 0-26cm/s
Edge banding material: PVC veneer, melamine plastic and other materials

3



Product number: KN-700
Power supply voltage: 380V/three-phase four-wire (3 live wire+1 zero wire)/50HZ/60HZ
Total power: 6KW
Air pressure: 0.6-0.8Mpa
Glue pot operating temperature: 110° -220°
Inverter: MD200 2.2KW industrial inverter
Docking laser displacement sensor: 1030
Edge band thickness: usually 0.5-3mm (related to edge band material)
Edge band width: 14-70mm
Edge banding speed: 0-37cm/s
Trimming board thickness: <12mm single-sided trimming, 12-70mm upper and lower double trimming (related to trimming knife)
Types of edge banding: PVC, veneer (need to be customized, plastic, melamine, etc.)
Packing size: 1550*1400 1350 (length*width*height mm) gross weight: ~500kg

Woodworking machine

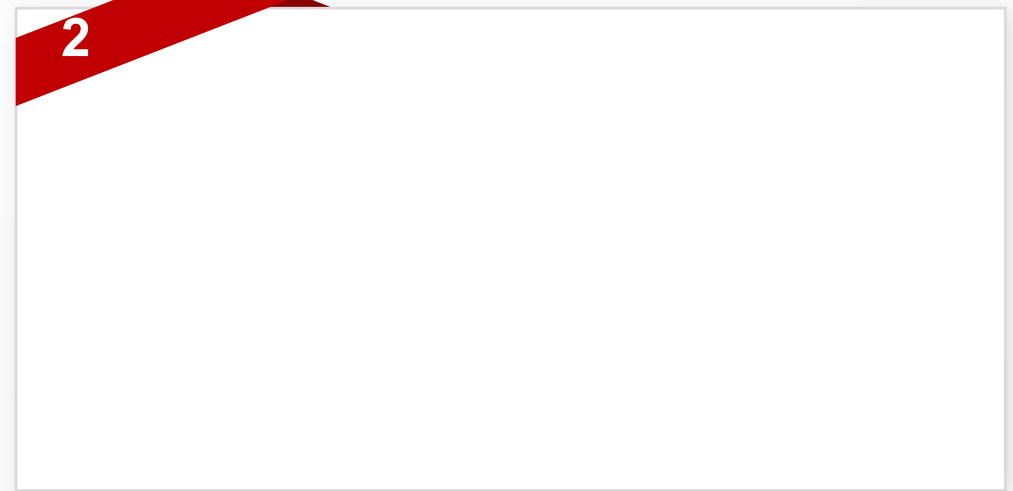

Model: AH703-1 (trimming machine)

Net weight: 1.8 kg

Size: 310×210×120mm

Total power: Watt

Voltage: 220V / 110V, 50~60 Hz

Speed: 30,000R/min

Packing size: 33*22*13cm

Package weight: 2.4KG

The total amount of the whole box:

19.5 kg (8 sets)

Volume: 905×305×220mm (8 sets

packed in a full box

Woodworking Planner

1



Model number: JBP503
Woodworking Planner
Maximum planing width: 300mm
Maximum planing depth: 5mm
Knife shaft speed: 5800rpm
Motor voltage/power:
380V/2.2kw
Whole machine weight: 220kg
Dimensions: 1800*760*1060mm

2



Model number: JBP504
Woodworking Planner
Maximum planing width: 400mm
Maximum planing depth: 5mm
Knife shaft speed: 5800rpm
Motor voltage/power: 380V/2.2kw
Whole machine weight: 280kg
Worktable size: 1800*445mm
Dimensions: 1800*800*1060mm

3



Model number: JBP505
Woodworking Planner
Maximum planing width: 500mm
Maximum planing depth: 5mm
Knife shaft speed: 5800rpm
Motor voltage/power: 380V/2.2kw
Whole machine weight: 390KG
Workbench size: 1800*520
Dimensions: 1800*520mm

Woodworking Planner

1



Model: JBP104

Maximum planing width: 400mm

Maximum planing thickness: 180mm

Minimum planing thickness: 3mm

Maximum planing amount: ≤ 4 mm

Planing length: ≥ 250 mm

Knife shaft speed: 6500rpm

Feeding speed: 6.8m/min

Motor voltage/power: 380V/4kw

Whole machine weight: 430kg

Dimensions: 760*830*1240mm

Wooden box packing size: 81*88*139cm

2



Model: JBP105

Maximum planing width: 500mm

Maximum planing thickness: 180mm

Minimum planing thickness: 3mm

Maximum planing amount: ≤ 4 mm

Planing length: ≥ 250 mm

Knife shaft speed: 6500rpm

Feeding speed: 6.8m/min

Motor voltage/power: 380V/4kw

Whole machine weight: 550kg

Dimensions: 760*930*1270mm

Wooden box packing size:
81*98*142cm

3



Model number: JBP106

Maximum planing width: 630mm

Maximum planing thickness: 180mm

Minimum planing thickness: 3mm

Maximum planing amount: ≤ 4 mm

Planing length: ≥ 250 mm

Knife shaft speed: 6500rpm

Feeding speed: 6.8m/min

Motor voltage/power: 380V/5.5kw

Whole machine weight: 600kg

Dimensions: 760*1060*1270mm

Wooden box packing size:
81*111*142CM

Wood planner machine

1



Model: GK001
Net weight: 27 kg
Dimensions: 600×500×400MM
Total power: 715 watts
Voltage: 220 volts, 50~60 Hz
Motor speed: 3000R/min
Air pressure: 4-5 kg/CM³
Thickness of repairable wood board:
10-60mm
Gross weight: 30 kg
Volume: 690×580×460mm

2

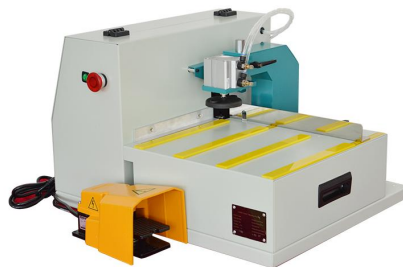

Model: GK002
Net weight: 32 kg
Dimensions: 600×500×400MM
Total power: 715 watts
Voltage: 220 volts, 50~60 Hz
Motor speed: 3000R/min
Air pressure: 4-5 kg/CM³
Thickness of repairable wood board:
10-60mm
Gross weight: 35 kg
Volume: 690×580×460mm

3



Model: GK001 mini
Net weight: 24 kg
Dimensions: 720×500×470MM
Total power: 680 watts
Voltage: 220 volts, 50~60 Hz
Motor speed: 22000R/min
Air pressure: 4-5 kg/CM³
Thickness of repairable wood board:
10-60mm
Gross weight: 25 kg
Volume: 730×490×460mm

Single motor saw table

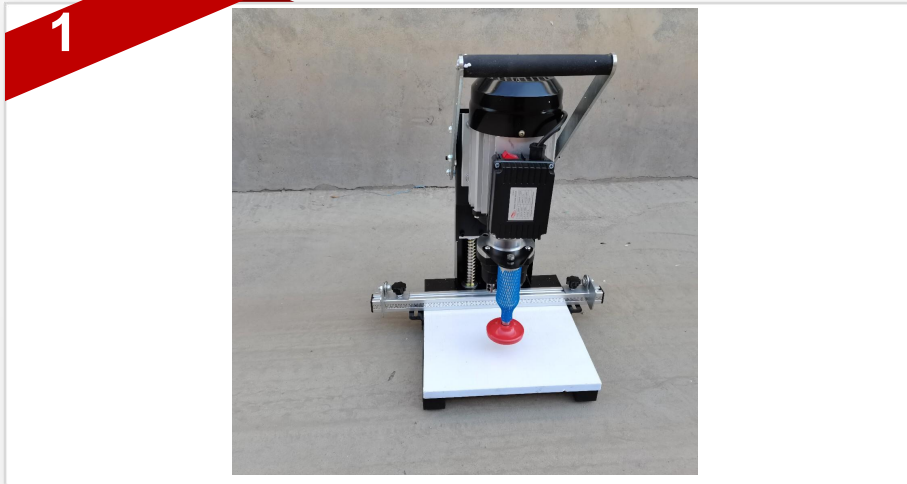

Power:1100W.
Voltage:220V.
Speed 2880/min.
Processing depth:0-40mm (custom made).
Drill bag model:48-6 (45-9.5).
Ruler 50 centimeters.
Dimension:470x420x580mm
Weight:25kg
Bits handle:10mm.
The thickest thickness of the machined sheet is 4 cm.
Use hinge hole, three-in-one 15 blind hole.
Continuous working time < 10H.
Packing size:36*40*65cm
Weight:21.5kgs



Power:1100W.
Voltage:380/220V.
Speed 2880/min.
Processing depth \leq 50mm.
Borehole diameter \leq 35mm.
Weight:60kg.
Gross weight:65kg.
The thickest thickness of the machined sheet is 5 cm.
Workbench size:700*400mm.
Dimension:800*600*1550mm (including package size)

Single motor saw table



Product model: JB06
Rated voltage: 220V/50HZ
Rated power: 1800W
No-load speed: 5000r/min
Blade size: 255×25.4×2.8mm
Cutting depth: 90° -85mm / 45° -65mm
Table size: 950×650mm
Saw blade height adjustment: 0-85mm
Film selection angle adjustment: 90° - 45°
Row full mouth diameter: 35.5mm
Packing full inch: 710*560*350mm
Gross weight/net weight: 24KG/22KG



Product model: JB07
Rated voltage: 220V/50HZ
Rated power: 2000W
No-load speed: 4500 /min
Saw blade specification: 250 X 25.4mm
Saw blade height adjustment: 0-85mm
Saw blade angle: 0-45°
Cutting size: 90° - 85 mm / 45° : 50 mm
Product weight: 36 kg
Packing size: 920X750X380mm

Double motor sawing machine

1



Model: JBT200
Saw blade 8 inches + 4 inches
Speed: small saw 13000 rpm / master saw 4500 rpm
Dust collection motor: 1.2kw
Large/small saw power: 2.6kw / 1.6kw
Saw table height: 70-75CM adjustable
Saw table Expand Size: 2200*2500*750mm
Saw table weight (without saw head): 94KG
Host size 500x300x350mm
Folding bracket, trolley design, 0.1CM thick stainless steel plate, 18MM multi-layer solid wood board,
Unit packaging size: 81*1000*590MM
weight: 100KG
Host packaging size: 550 * 360 * 420MM
weight: 31KG packaging weight: 141KG

2



model: JB09A (electric lifting double motor cutting machine)
Motor power: 2200W + 1280W Dust removal motor power: 1100W
Voltage frequency: 220V / 50hz 60hz
Saw blade speed: 4500 rpm for big saw, 13800 rpm for small saw
Big saw: 8 inches-small saw: 4 inches
Saw blade thickness: large saw blade teeth 2.5mm
small saw blade teeth 2.8mm
Cutting depth: 0-50mm
Dust collection rate: above 99%
Whole machine weight: 25KG
Fan power: 1100W
Product size: 540* 295* 326mm
Packing size: 550mm * 360mm * 400mm
Scope of application: solid wood flooring, laminate flooring/bamboo flooring/PVC plastic board/cork flooring, etc.

3



Model: JB09 (Manual Lifting Double Motor Cutting Machine)
Motor power: 2200W + 1280W Dust removal motor: 1100W
Voltage frequency: 220V / 50hz 60hz
Saw blade speed: 4500 rpm for big saw, 13800 rpm for small saw
Size saw size: 8 inches-4 inches
Saw blade thickness: large saw blade teeth 2.5mm small saw blade teeth 2.8mm
Cutting depth 0-50mm
Dust removal rate is over 99%
Product size: 54cm * 29.5cm * 32.6cm
Packing size: 55cm * 36cm * 40cm
Scope of application: solid wood flooring, laminate flooring/bamboo flooring/PVC plastic board/cork flooring, etc.

Double motor sawing machine

1



2



3



WJ-80
Saw blade 8 inch + 4 inch
Speed: small saw 13000 rpm / mother saw 4500 rpm
Vacuum motor: 1.2kw
Large/small saw power: 2.6kw/1.6kw
Saw table height: 70-75CM adjustable
Saw table weight without saw machine: 54KG
Host size 500x300x350mm
Folding stand, trolley design, 0.1CM thick stainless steel plate, 18MM multi-layer solid wood board,
Package size: 112*68*50CM
saw table net weight 54KG
Weight: 60KG
Host packaging size: 550*360*420MM
Host net weight 25KG
Weight: 31KG
Whole set weight: 104KG

model: JB09A (electric lifting double motor cutting machine)
Motor power: 2200W + 1280W Dust removal motor power: 1100W
Voltage frequency: 220V / 50hz 60hz
Saw blade speed: 4500 rpm for big saw, 13800 rpm for small saw
Big saw: 8 inches-small saw: 4 inches
Saw blade thickness: large saw blade teeth 2.5mm small saw blade teeth 2.8mm
Cutting depth: 0-50mm
Dust collection rate: above 99%
Whole machine weight: 25KG
Fan power: 1100W
Product size: 540* 295* 326mm
Packing size: 550mm * 360mm * 400mm
Scope of application: solid wood flooring, laminate flooring/bamboo flooring/PVC plastic board/cork flooring, etc.

Model: JB09 (Manual Lifting Double Motor Cutting Machine)
Motor power: 2200W + 1280W Dust removal motor: 1100W
Voltage frequency: 220V / 50hz 60hz
Saw blade speed: 4500 rpm for big saw, 13800 rpm for small saw
Size saw size: 8 inches-4 inches
Saw blade thickness: large saw blade teeth 2.5mm small saw blade teeth 2.8mm
Cutting depth 0-50mm
Dust removal rate is over 99%
Product size: 54cm * 29.5cm * 32.6cm
Packing size: 55cm * 36cm * 40cm
Scope of application: solid wood flooring, laminate flooring/bamboo flooring/PVC plastic board/cork flooring, etc.

Single motor saw table



1
WJ-80 MAX
Saw blade 8 inch + 4 inch
Speed: small saw 13000 rpm / mother saw 4500 rpm
Vacuum motor: 1.2kw
Large/small saw power: 2.6kw/1.6kw
Saw table height: 70-75CM adjustable
Saw table weight without saw machine: 54KG
Host size 500x300x350mm
Folding stand, trolley design, 0.1CM thick stainless steel plate, 18MM multi-layer solid wood board,
Package size: 112*68*50CM
saw table net weight 54KG
Gross weight: 70KG
Host packaging size: 550*360*420MM
Host net weight 25KG
Weight: 31KG
Whole set weight: 101KG



2
Model: JBT200 MAX
Saw blade 8 inches + 4 inches
Speed: small saw 13000 rpm / master saw 4500 rpm
Dust collection motor: 1.2kw
Large/small saw power: 2.6kw / 1.6kw
Saw table height: 70-75CM adjustable
Saw table Expand Size: 2200*2500*750mm
Saw table weight (without saw head): 94KG
Host size 500x300x350mm
Folding bracket, trolley design, 0.1CM thick stainless steel plate, 18MM multi-layer solid wood board,
Unit packaging size: 81 * 1000 * 590MM
weight: 100KG
Host packaging size: 550 * 360 * 420MM
weight: 31KG packaging weight: 131KG

Double motor sawing machine

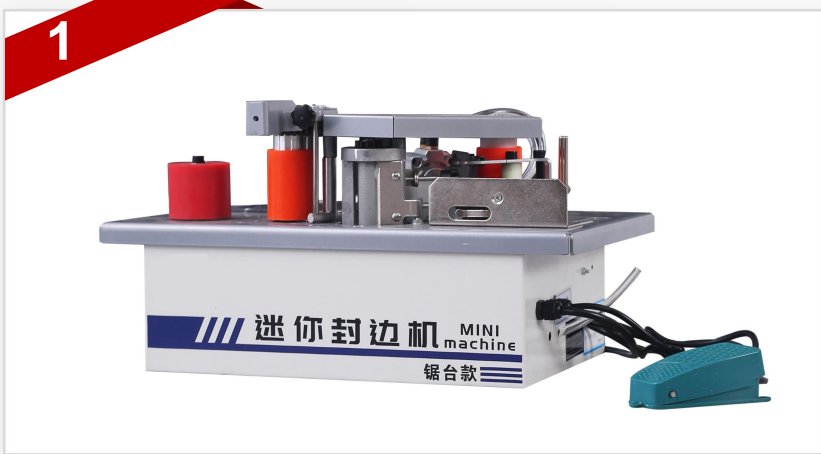

Model: S-200
Net weight: 13.5kg
Dimensions: 530*350*310MM
Total power: 825 watts
Voltage: 220V
Edge band thickness: 0.3-3MM
Edge band width: 7-60MM
Feed speed: 0-6 m/min
Working temperature: 120-180° C
Gluing method: double-sided
gluing
Gross weight: 15KG



Model: R-200
Net weight: 6kgs
Dimensions: 31*22*27cm
Total power: 1600w
Voltage: 220V/110V 50-60HZ
Gross weight: 7kg



Model: S-220
Net weight: 19 kg
Dimensions: 600*400*280MM
Total power: 1150 watts
Voltage: 220V/110V, 50~60 Hz
Edge band thickness: 0.3-3MM
Edge band width: 10-60MM
Feed speed: 0.5-5 m/min
Working temperature: 120-180° C
Gluing method: double-sided gluing
Gross weight: 20KG

Double motor sawing machine

1



2



2



JBT480
 Saw blade 8 inch + 4 inch
 Speed: small saw 13000 rpm / mother saw 4500 rpm
 Vacuum motor: 1.2kw
 Large/small saw power: 2.6kw/1.6kw
 Saw table height: 70-75CM adjustable
 Saw table weight without saw host: 65KG
 Host size 500x300x350mm
 Folding stand, trolley design, 0.1CM thick stainless steel plate, 18MM multi-layer solid wood board,
 Package size: 51*84*112 MM
 Countertop net weight 70KG
 Gross Weight:80KG
 Host packaging size: 550*360*420MM
 Host net weight 25KG
 Weight: 31KG
 Whole set weight: 111KG

WJ-3
 Saw blade 8 inch + 4 inch
 Speed: small saw 13000 rpm / mother saw 4500 rpm
 Vacuum motor: 1.2kw
 Large/small saw power: 2.6kw/1.6kw
 Saw table height: 70-75CM adjustable
 Saw table weight without saw head: 74KGS
 Host size 500x300x350mm
 Push table type: rocker arm push table
 Folding stand, trolley design, 0.1CM thick stainless steel plate, 18MM multi-layer solid wood board,
 Saw table unfolded size: 258*260*75cm
 Saw table wooden box packing size: 77*109*48CM
 Countertop net weight 74KG
 Weight: 91KG
 Host packaging size: 550*360*420MM
 Host net weight 25KG
 Gross weight: 31KG
 Whole set weight: 122KG

Item model number: JBT300
 Machine unfolded size: 295*283*85cm
 Rated voltage: 220V
 Folded size: 130*85*100cm
 Big saw power: 2.6KW
 Machine weight: 137KG
 Small saw power: 1.6KW
 Track: double linear precision guide rail
 Vacuuming power: 1.2kw
 Flip board: 67*37cm thickness 8mm
 Saw speed: large 4500 r/min small 12000 r/min
 Countertop thickness: 1.5mmmm
 Saw blade size:4+8 inches
 Packing size: length 1330mm*900mm*108mm
 Gross weight: 150KG

Double motor sawing machine

1



2

3

Push table size: 3200*330*375mm

Maximum sawing length: 3200mm.

Maximum sawing width: 1250mm.

Maximum sawing thickness: 80mm.

Slotted saw blade speed: 8000-9000r/min.

Main saw blade size: outer diameter 300mm/
inner diameter 30mm.

Groove saw blade size: outer diameter 120mm/
inner diameter 20mm.

Speed of main saw shaft: 5000-6000r/min.

Spindle diameter: 30mm.

Motor power 4kw+0.75kw.

Saw blade angle: 0-45 ° .

Form factor: 3200*1100*1200mm.

Gross weight: 600kg

Multifunction Double motor sawing machine

1



Model: JBS220 Precision Saw
Saw blade: 4+8 inches
Speed: 7800 rpm for small saw / 4800 rpm for mother saw
Dust collection motor: 1.2kw
Large/small saw power: 2.68kw/1.18kw
Saw table height: 75-80cm adjustable
Saw table weight including saw host: 120KG
Host size: 1700x2700x770mm
Folding stand, trolley design, 0.1CM thick stainless steel sheet, 18MM multi-layer solid wood board
Precision Saw packing size: 970*810*670MM
Gross weight: 140KG
Function: 45/90 degree cutting, electric lifting

2



Model: JBS220 MAX Precision Saw
Saw blade: 4+8 inches
Speed: 7800 rpm for small saw / 4800 rpm for mother saw
Dust collection motor: 1.2kw
Large/small saw power: 2.68kw/1.18kw
Saw table height: 75-80cm adjustable
Saw table weight including saw host: 120KG
Host size: 1700x2700x770mm
Folding stand, trolley design, 0.1CM thick stainless steel sheet, 18MM multi-layer solid wood board
Precision Saw packing size: 970*810*670MM
Edge bander packing size: 615*410*300mm
Gross weight: 168KG
Function: 45/90 degree cutting, electric lifting, milling, drilling and edge banding

3

Woodworking tools

1

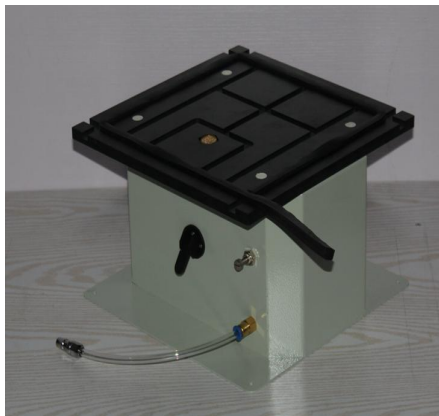

model: V90 (vacuum suction cup)
Net weight: 5 kg
Dimensions: 300×300×190mm
Vertical suction power: 70 kg
Horizontal suction: 150 kg
Air pressure: 4-5 kg/cubic
centimeter
Gross weight: 6 kg
Packing: 1pc/carton
Volume: 320×320×220mm

2



model: V80 (Glass suction cup)
Net weight: 1.5 kg
Dimensions: 120×120×310mm
Vertical suction power: 30 kg
Horizontal suction power: 60 kg
Gross weight: 5 kg
Packing: 3 pcs/group

3



Product model: JB320
Net weight: 1.1 kg
Size 70×100×125 mm
The thickness of the edge band
can be cut off: 0.3-3mm
The width of the sideband can
be cut off: 10-55mm
Packing: 10 pcs/carton
Gross weight: 11.5 kg
Volume: 720×315×300mm

Woodworking tools

1



model: JB70

Net weight: 200 grams

Dimensions: 140×80×90mm

The thickness of the edge band can be cut off: 0.3-0.6mm

The width of the edge band can be cut off: 10-60mm

Gross weight: 11 kg

Packing: 50 pcs/carton

Volume: 520×330×500mm

2



model: JB06

Net weight: 150 grams

Dimensions: 100×50×60MM

Repairable edge band thickness: 0.3-0.6MM

Repairable edge band width: 10-60MM

Gross weight: 9 kg

Packing: 50 pcs/carton

Volume: 450×320×460mm

3



model: JB50

Net weight: 200 grams

Dimensions: 120×60×20mm

Repairable edge band thickness: 0.3-10mm

Repairable edge band width: 10-60mm

Gross weight: 0.2 kg

Packing: 50 pcs/carton

Volume: 450×320×460mm

Woodworking tools



Product model: JBK35

Name: Woodworking 35 Hinge Hole Locator

Material aluminum alloy 6161

Size: length 120mm × width 60mm × height 120mm

Features: precision manufacturing, quality assurance, accurate scale, convenient operation

Use 35MM chain hole

Packing size: 210*95*125mm

Weight: 660g 25 sets per carton Packing size: 54*38*36CM Weight: 17 kg



Product model: JB14

Name: Woodworking hinge hole locator

Features: precision manufacturing, quality assurance, accurate scale, convenient operation

Use 35MM chain hole

Package weight: 670 grams

Packing size: 260*165*60mm

Packing size: 640*280*370mm 20pcs/box

Woodworking tools



Product model: JB31
Product name: three-in-one locator.
Clamping range: 0-52mm.
Product material: aluminum.
Product use: woodworking positioning punch
Packing size: 175*175*65mm.
Packing weight: 1kg



Product model: JBP08
Product name: Edge banding puncher
Punching width: 8mm.
Product material: aluminum.

Woodworking tools



Product model: JB45

Product name: 45° trimmer

Packing size: 170*80*40mm.

Packing weight: 0.4kg



Product model: JB04

Product name: woodworking right angle locator

Packing size: 200*180*60mm.

Packing weight: 0.5kg

Toolbox

1

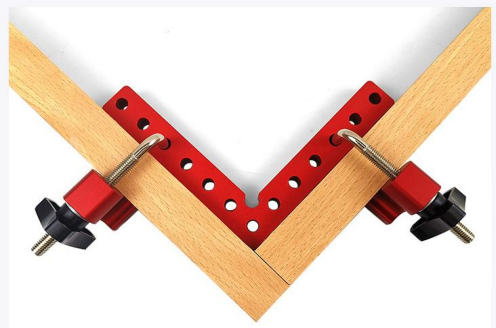

2



3



4

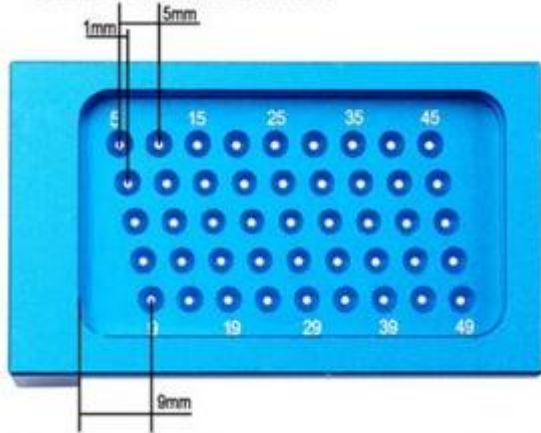

5

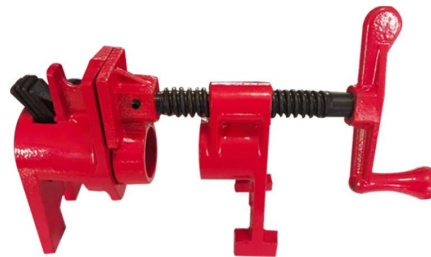

6



High quality hot melt edge banding glue

1

JB001 Edge
Banding Adhesive



2

JB002 Edge
Banding Adhesive



3

JB003 Edge
Banding Adhesive



Accessories

1

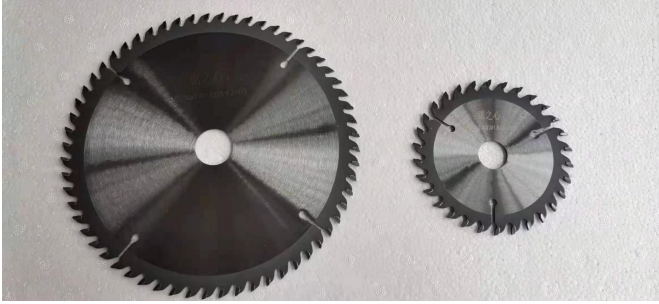

Big and small saw blade

2



Enhanced trimming knife

3



Standard trimming knife

4

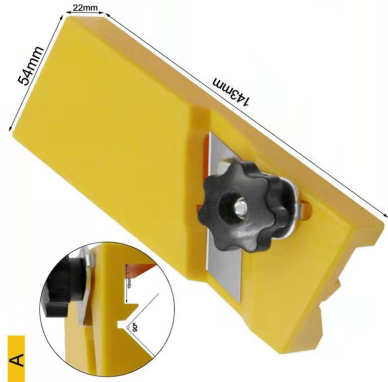

45 degree trimmer

5



Furniture hinge

6



Three-in-one link

Welcome to be our global partner

1

Our advantage

Jackbond has been engaged in international trade for 12 years and has its own R&D technical team

2

What quality services can we provide you?

Jackbond has established a procurement team composed of technicians + salesmen in 2018. In order to meet the procurement needs of all partners, we can provide you with more high-quality products from China.

3

How to solve the problem of high product transportation cost?

After years of national trade accumulation, Jackbond has reached strategic cooperation with large logistics companies in China, sea, air, express, and railway transportation channels, and can provide you with high-quality logistics services.

A large, abstract graphic composed of a network of interconnected nodes and lines, forming a shape that resembles a stylized 'S' or a wave. The nodes are small black dots, and the lines are thin black lines. The graphic is centered on the page and has a color gradient from dark grey/black on the left to light orange/gold on the right.

THANK YOU